

5SC3528W32F0WPZ1

- ▣ **Outline(L*W*H) : 3.5*2.8*1.9mm**
- ▣ **High flux efficiency & Energy conservation**
- ▣ **Good thermal dissipation & Optical uniformity**



Table of Contents

Product Code Method -----	2
Maximum Rating-----	2
Typical Product Characteristics-----	3
Range of Bins-----	3
Color Coordinate Comparison-----	4
Electronic-optical Characteristics-----	5
Dimensions-----	6
Reflow Profile-----	7
Test Circuit and Handling Precautions-----	8
Packing-----	9
Precautions-----	11

Features

- Forward current: $\leq 80\text{mA}$
- Typical view angle 50% Iv: 120°
- RoHS2.0 and REACH-compliant
- Lens color: yellowish
- MSL 2a qualified according to JEDEC J-STD20D
- ESD Level 6kV(HBM)
- Reliability Test: AEC Q-102 qualified

Applications

- Indoor signage display applications
- Indoor decorating and entertainment design
- Flat backlight for LCD. Switch and symbol
- Automotive electronics
- Special applications

■ Product Code Method

5 - S - C - 3528 - W32F - 0 - W - P - Z1

① ② ③ ④ ⑤ ⑥ ⑦ ⑧ ⑨

①	②	③	④	⑤
Process Type	Category	LED Type	Lead Frame	Dice Wavelength & Luminous Rank
5 : special product	S: SMD LED	C: PLCC top view D: PLCC side view	3528: 3.5*2.8mm	Wxxx: White

⑥	⑦	⑧	⑨
Lap Polarity	Lens Color	Bracket or COB Specifications	Assembly Code
0: non-common anode and non-common cathode	W: yellowish	P: article mode	Z: Zener 1: no expression above meaning for company

■ Maximum Rating(Ta=25°C)

Characteristics	Symbol	Rating	Unit
DC forward current	I _F	80	mA
Pulse forward current ^{*3}	I _{PF}	200	mA
Reverse voltage	V _R	5	V
Junction temperature	T _J	125	°C
Operating temperature range	T _{OP}	-40-105	°C
Storage temperature range	T _{STG}	-40-105	°C
Soldering temperature ^{*4}	T _{SD}	260	°C
Thermal Resistance Junction/Solder Point	R _{th}	150	°C/W

Notes 1: There is no maximum or typical voltage parameter

2: For other ambient, limited setting of current will be depended on de-rating curves.

3: Duty 1/10, pulse width 0.1ms

4: The maximum of soldering time is 5 seconds in T_{SD}

■ Typical Product Characteristics (Ta=25°C)

Characteristics	Symbol	Min.	Typ.	Max.	Unit	Test condition
Forward Voltage	V _F	2.8	-	3.6	V	I _F =70mA
Reverse Current	I _R	-	-	10	μA	V _R =5V
Luminous Lumen	Φ	18	23	-	lm	I _F =70mA
Color Coordinate	x	-	0.321	-	-	I _F =70mA
	y	-	0.336	-	-	
View Angle	2θ _{1/2}	-	120	-	deg	I _F =70mA

Notes: 1. Measurement Errors:

Forward Voltage: ±0.1V, Luminous Intensity: ±10%I_v, Color Coordinate: ±0.006, View Angle (2θ_{1/2}) ±5%

2. Electrical-Optical Characteristics (Ta=25°C)

■ Range of Bins
1). Forward Voltage Bins(I_F=70mA)

Bin code	Min. V _F (V)	Max. V _F (V)
B	2.8	2.9
C	2.9	3.0
D	3.0	3.1
E	3.1	3.2
F	3.2	3.3
G	3.3	3.4
H	3.4	3.5
I	3.5	3.6

2). Luminous Intensity Bins(I_F=70mA)

Bin Code	Min. Φ (lm)	Max. Φ (lm)
B15	18	20
B16	20	22
B17	22	24
B18	24	26
B19	26	28

■ Color Coordinate Comparison

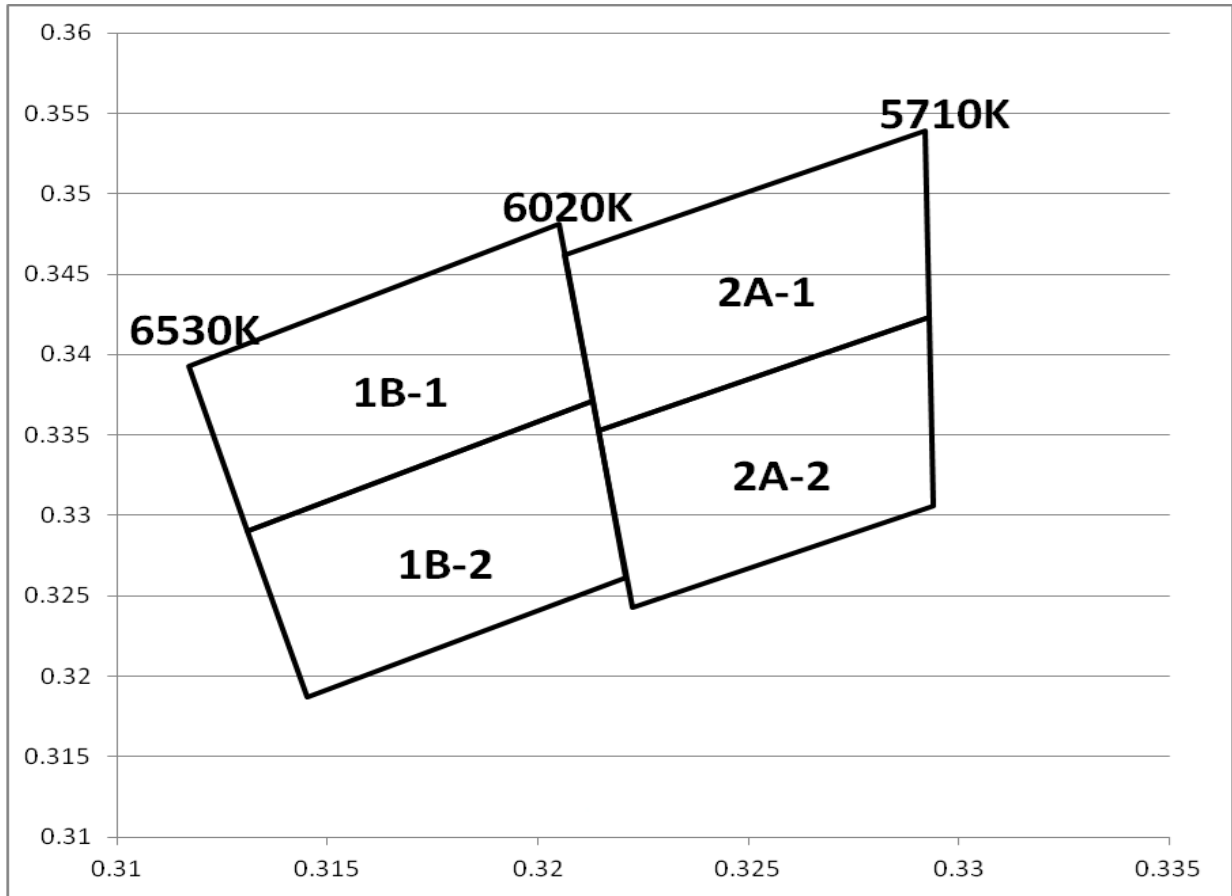

Color Rank

BIN	X	Y	X	Y	X	Y	X	Y
1B-1	0.3205	0.3481	0.3117	0.3393	0.3131	0.329	0.3213	0.3371
1B-2	0.3213	0.3371	0.3131	0.329	0.3145	0.3187	0.3221	0.3261
2A-1	0.3292	0.3539	0.32064	0.3462	0.32143	0.3353	0.3293	0.3423
2A-2	0.3293	0.3423	0.32143	0.3353	0.32223	0.3243	0.3294	0.3306

■ Relative Spectral Power Distribution

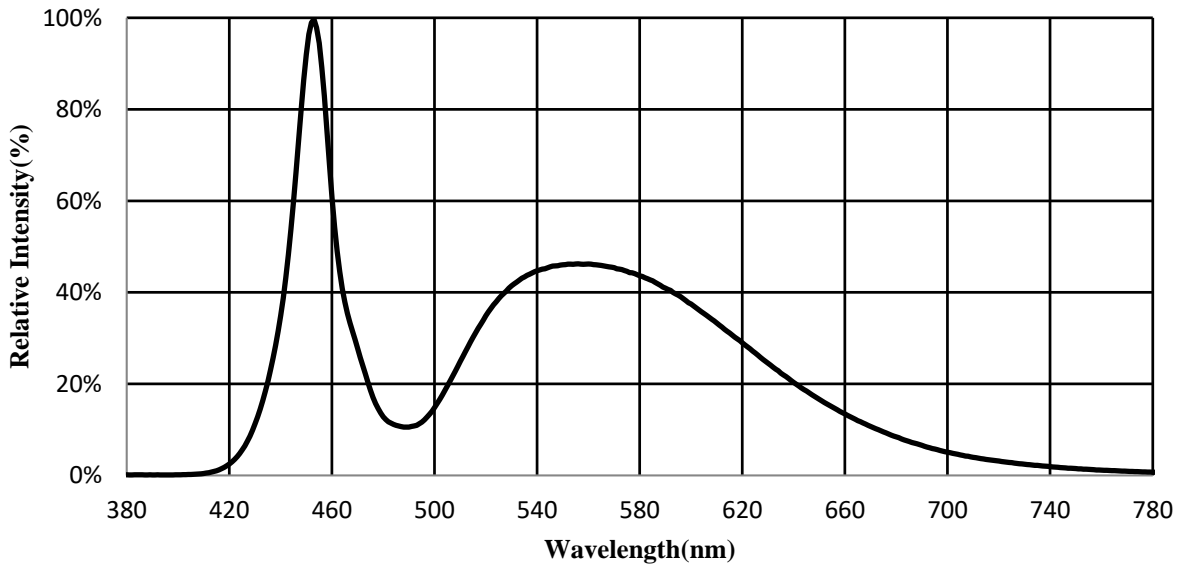

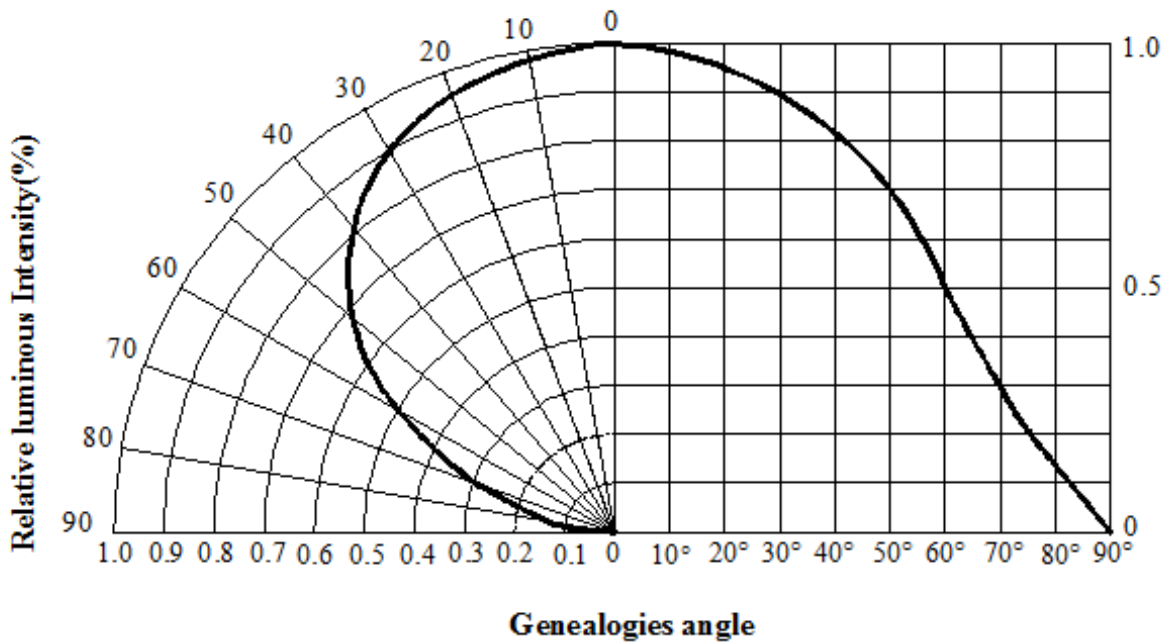
■ Typical Diagram Characteristics of Radiation

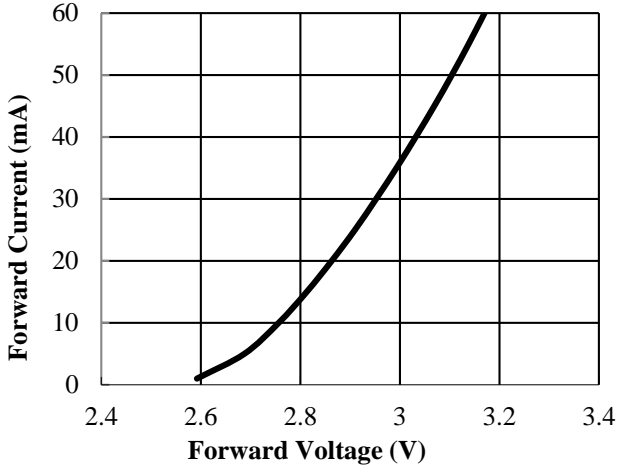
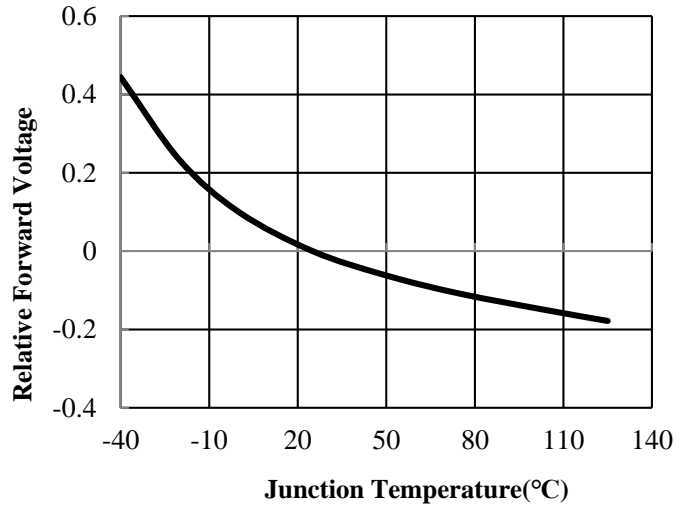
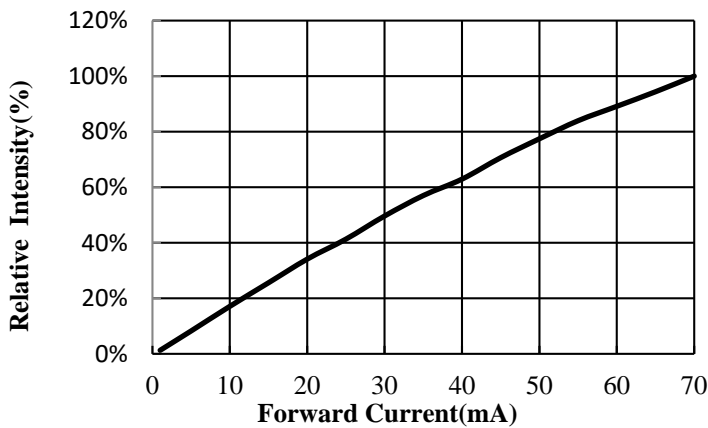
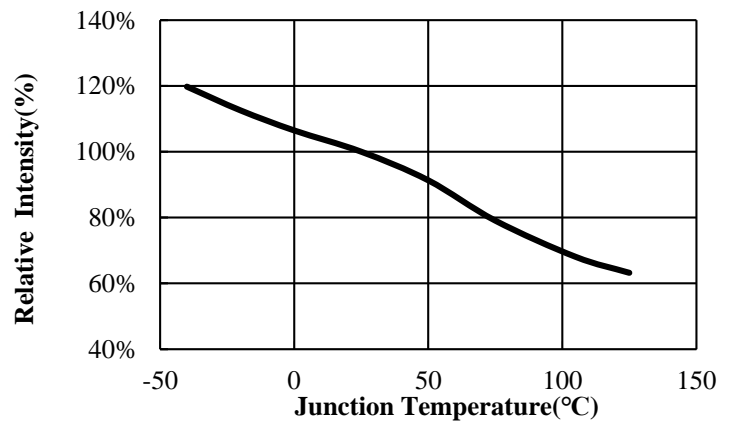
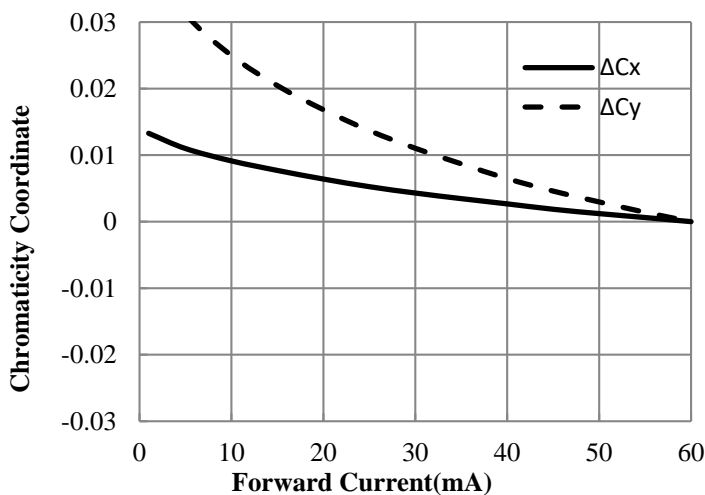
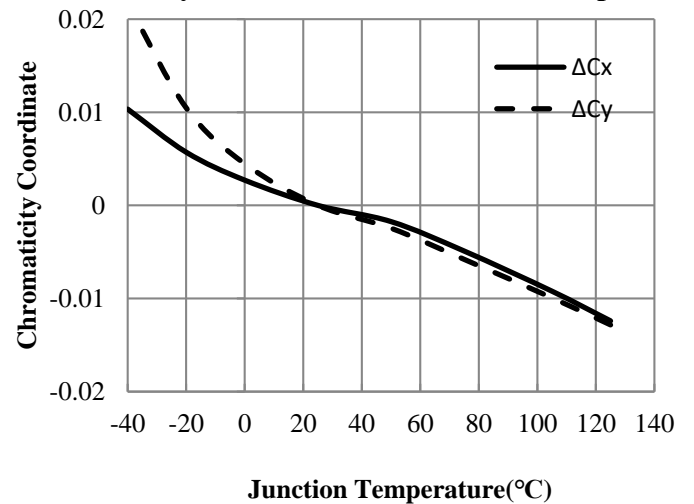

■ Electrical-Optical Characteristics
Forward Current vs. Forward Voltage

Forward Voltage vs. Junction Temperature

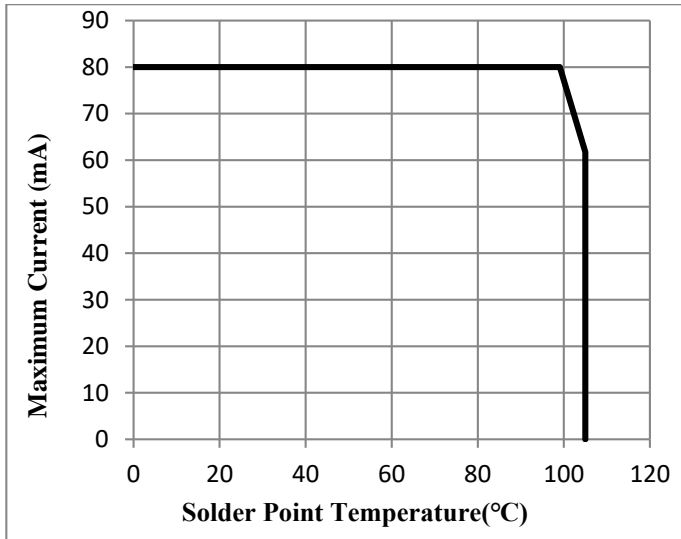
Relative Intensity vs. Forward Current

Relative Intensity vs. Junction Temperature

Chromaticity Coordinate vs. Forward Current

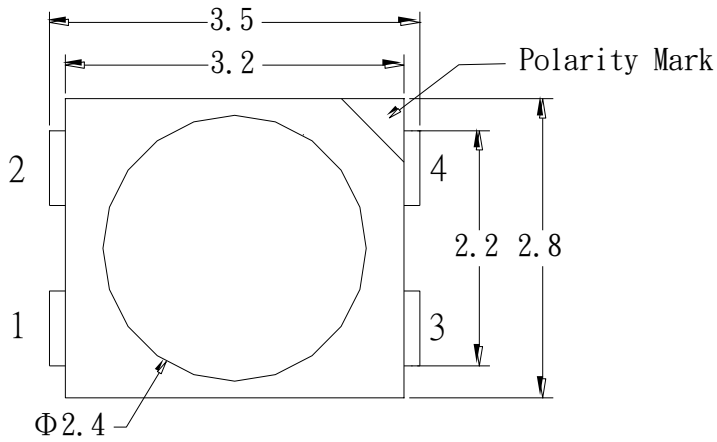
Chromaticity Coordinate vs. Junction Temperature

■ Thermal Design for De-rating

The maximum forward current is determined by the thermal resistance between the LED junction and solder point. It is crucial for the end product to be designed in a manner that minimizes the thermal resistance from the solder point to ambient in order to optimize lamp life and optical characteristics.



■ Dimensions



Top View

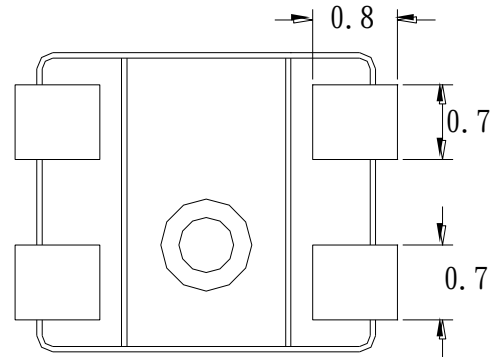

Bottom View

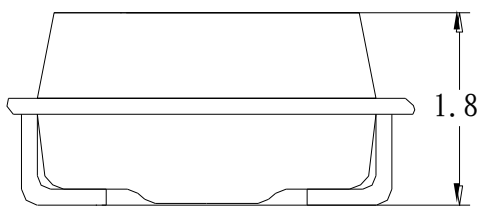

Side View

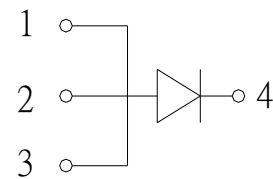

Polarity

Recommend pad layout

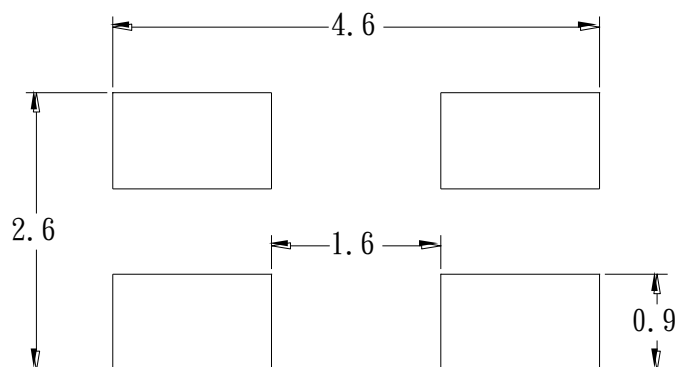

RECOMMEND PADLAYOUT

- Notes: 1. All dimensions are in millimeters (inches)
 2. Tolerance is ± 0.1 (± 0.004 ")mm unless otherwise noted
 3. Specifications are subject to change without notice.

■ Reflow Profile

SMT Reflow Soldering Profile

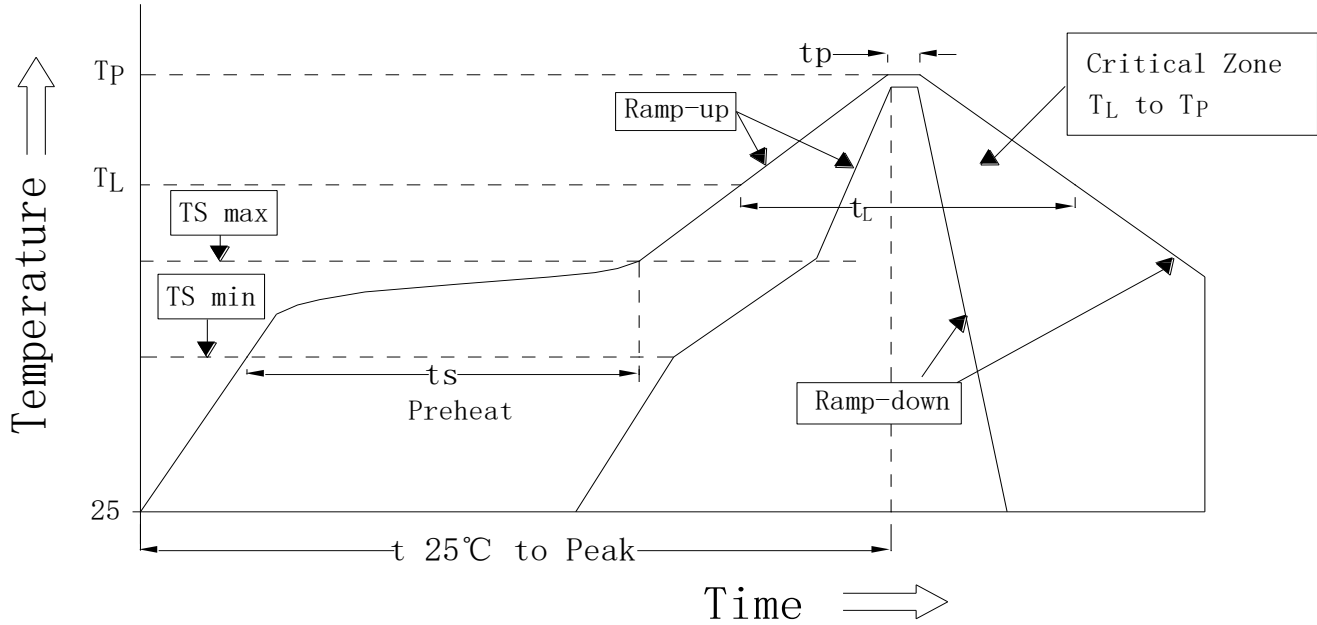

Profile Feature	Symbol	Pb-Free (SnAgCu) Assembly			Unit
		Min.	Recommendation	Max.	
Ramp-up rate to preheat (25°C to 150°C)	-	-	2	3	K/s
Time t_s ($T_{S\ min}$ to $T_{S\ max}$)	t_s	60	100	120	s
Ramp-up rate to peak ($T_{S\ max}$ to T_P)	-	-	2	3	K/s
Liquidus temperature	T_L	-	217	-	°C
Time above liquidus temperature	t_L	-	80	100	s
Peak temperature	T_P	-	245	260	°C
Time within 5 °C of the specified peak temperature $T_P - 5\ K$	t_p	-	-	10	s
Ramp-down Rate (T_P to 100 °C)	-	-	3	4	K/s
Time 25 °C to T_P	-	-	-	480	s

Notes:

1. Do not stress the silicone resin while it is exposed to high temperature.
2. The reflow process should not exceed 3 times.

■ Test Circuit and Handling Precautions

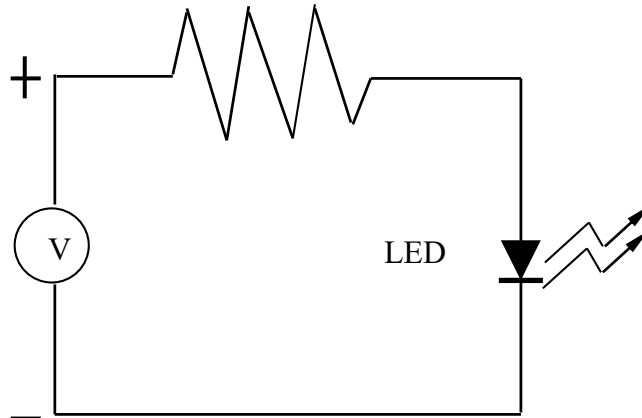
1. Test Circuit

2. Handling Precautions
2.1. Over-current-proof

Customer must apply resistors for protection; otherwise slight voltage shift will cause big current change (Burn out will happen).

2.2. Storage

1). It is recommended to store the products in the following conditions:

Humidity: 60% R.H. Max.

Temperature: 5°C~30°C (41°F~86°F)

2). Shelf life in sealed bag: 12 month at <5°C~30°C and <60% R.H. after the package is Opened, the products should be used within four weeks or they should be keeping to stored at $\leq 20\%$ R.H. with zip-lock sealed.

2.3. Baking

If the package has been opened for more than 4 weeks or over than 12 months in sealed bag, it is recommended to bake the products with the following instruction:

1). 60±3°C X 6hrs and <5%RH, for reel

2). 125±3°C X 2hrs, for single LED

It shall be normal to see slight color fading of carrier (light yellow) after baking in process

■ Packing

● Feeding Direction (Unit: mm)

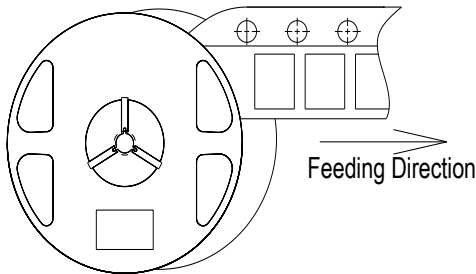

● Dimensions of Reel (Unit: mm)

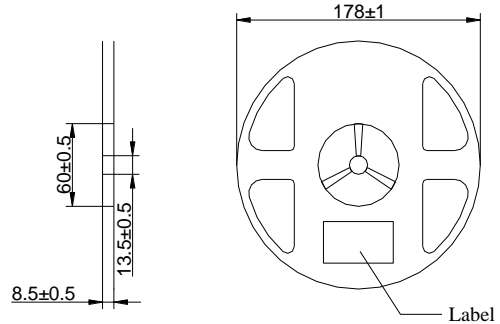

● Dimensions of Tape (Unit: mm)

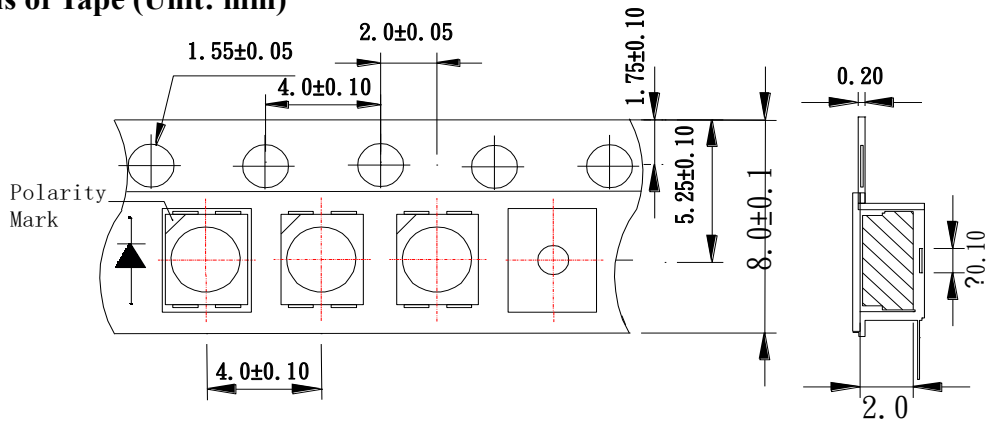

● Arrangement of Tape

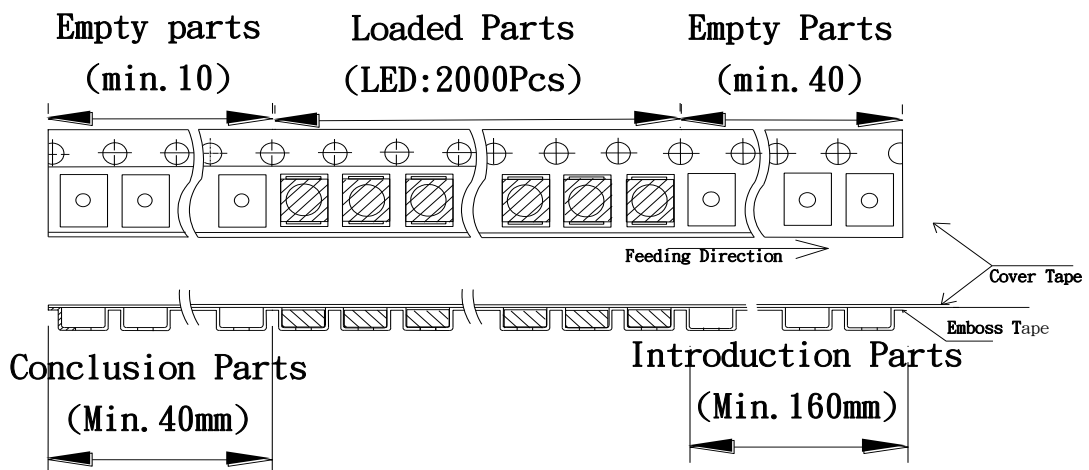

Notes:

1. Empty component pockets are sealed with top cover tape
2. The max loss number of SMD is 2pcs;
3. The cathode is oriented towards the tape sprocket hole in accordance with ANSI/EIA RS-481 specifications;
4. 2,000pcs per reel;
5. The remainder packing in multiples of 500pcs.

■ Packing

● Packaging Specifications

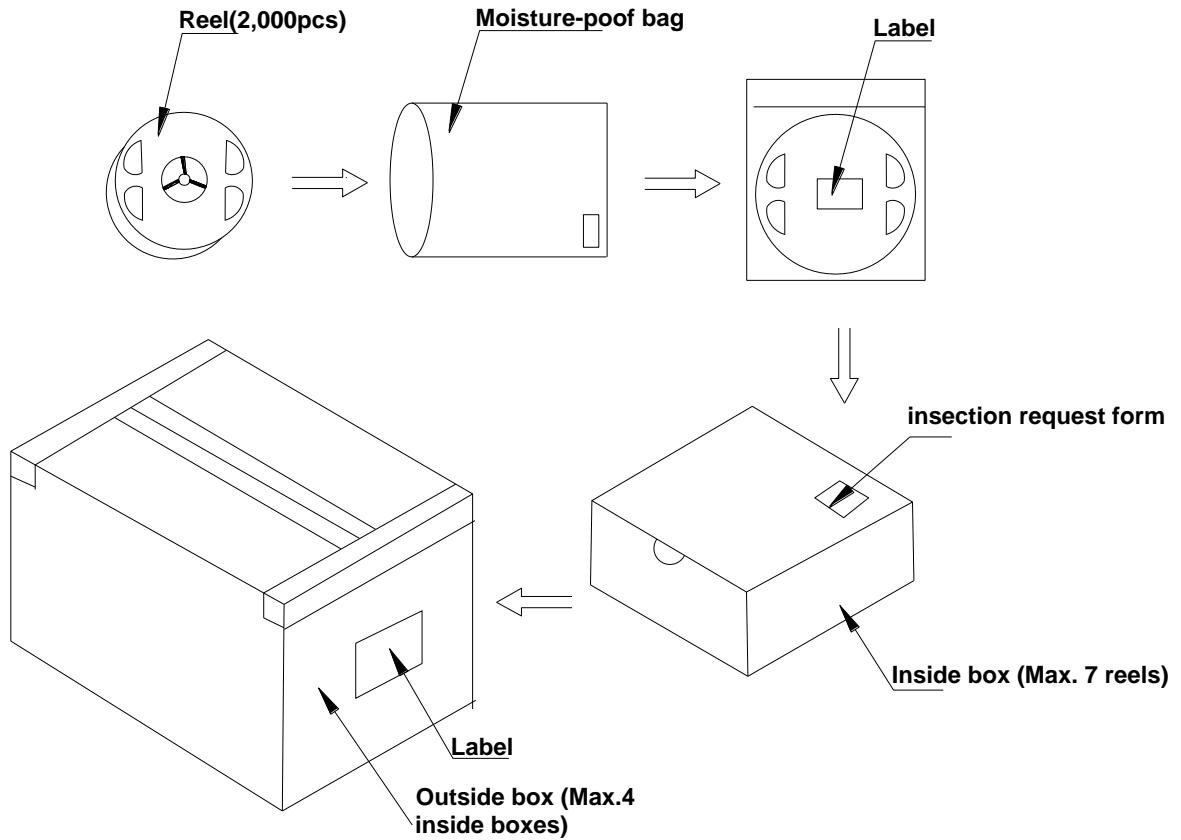

Notes:

Reeled product (max.2,000) is packed in a sealed moisture-proof bag. Seven bags are packed in an inner box (size: about 260 X 230 X 100 mm) and four inner boxes are in an outer box (size: about 480 X 275 X 215 mm). On the label of moisture-proof bag, there should be the information of Part No., Lot No. and quantity number; also the total quantity number should be on inspection request form on outer box.

■ Precautions

1. Abnormal situation caused by improper setting of collet

To choose the right collet is the key issue in improving the product's quality. LED is different from other electronic components, which is not only about electrical output but also for optical output. This characteristic made LED more fragile in the process of SMT. If the collet's lowering down height is not well set, it will bring damage to the gold wire at the time of collet's picking up and loading which will cause the LED fail to light up, light up now and then or other quality problems

2. How to choose the collet

During SMT, please choose the collet that has larger outer diameter than the lighting area of lens, in case that improper position of collet will damage the gold wire inside the LED. Different collets fit for different products, please refer to the following pictures cross out

Outer diameter of collet should be larger than the lighting area

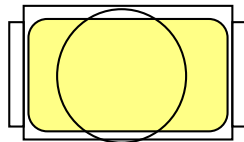

Picture 1(√)

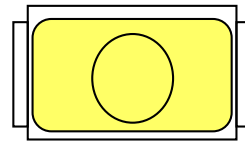

Picture 2(X)

3. Other points for attention

A. No pressure should be exerted to the epoxy shell of the SMD under high temperature.

B. Do not scratch or wipe the lens since the lens and gold wire inside are rather fragile and cross out easy to break.

C. LED should be used as soon as possible when being taken out of the original package, and should be stored in anti-moisture and anti-ESD package.

4. This usage and handling instruction is only for your reference.